

J.L. WINGERT CO.

Specification Sheet FLAT BOTTOM BYPASS FEEDERS MODEL []HD

SS030001.C 05/16

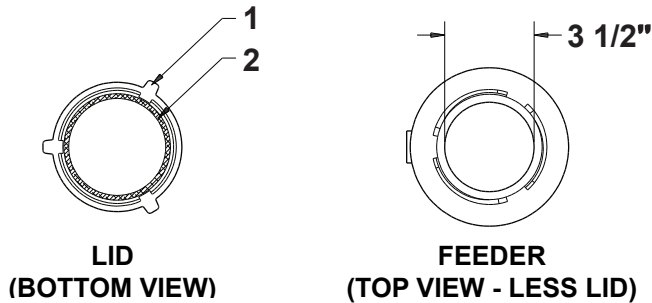

SPECIFICATIONS

KEY	PART	DESCRIPTION
1	3071	CLOSURE: 3 1/2" cast iron, 1/4 turn closure, (O-ring included)
2	3072	O-RING: Buna-N O-ring 200° F
3		BODY: Carbon steel
4		INLET: 3/4" FNPT
5		OUTLET: 3/4" FNPT
MAX. PRESSURE		200 PSI (13.7 BAR)
MAX. TEMPERATURE		200° F (93° C)

VOLUME (FILL CAPACITY)

MODEL	GALLONS	LITERS
2HD	2.16	8.17
5HD	5.79	21.92
12HD	12.76	48.30
18HD	19.22	72.75

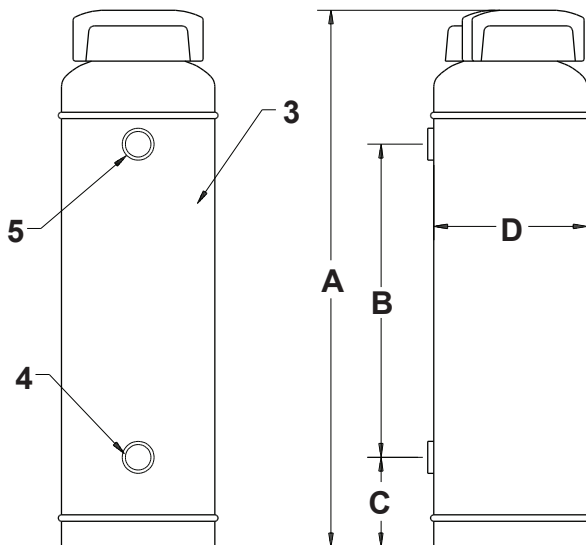

DIMENSIONS

KEY	2HD	5HD	12HD	18HD
A	21 1/8"	21 1/8"	41 3/4"	60 5/8"
B	12 1/2"	10 5/8"	31"	44"
C	3 1/4"	4 1/4"	4 1/8"	8 1/2"
D	6"	10"	10"	10"
WEIGHT	19 lbs. approx.	33 lbs. approx.	57 lbs. approx.	79 lbs. approx.
SHIPPING DIMENSIONS	6" x 6" x 22"	10" x 10" x 22"	10" x 10" x 44"	10" x 10" x 63"

Note: All dimensions are +/- 1/8". All weights are approximate. All dimensions are subject to change without notice.

MANUFACTURING: Mixers, Bypass Feeders, Filter Feeders, Bromine Feeders, Sample Coolers, Sludge Traps, Separators, Separator Systems, Tank Stands, Tank Package Systems, Glycol Feed Systems, Coupon Racks, Control Stations, NEMA Enclosures, Custom Packaged Systems and Specialty Welding

P.O. Box 6207 | Garden Grove, CA 92846-6207 / 11800 Monarch St. | Garden Grove, CA 92841-2113 | Phone (714) 379-5519 | Fax (714) 379-5549
Northern California Region | Phone (510) 487-5310 | Southwest Region | Phone (602) 470-1015 | Email: customerservice@jllwingert.com

www.jllwingert.com